

Caterpillar Drive Chain

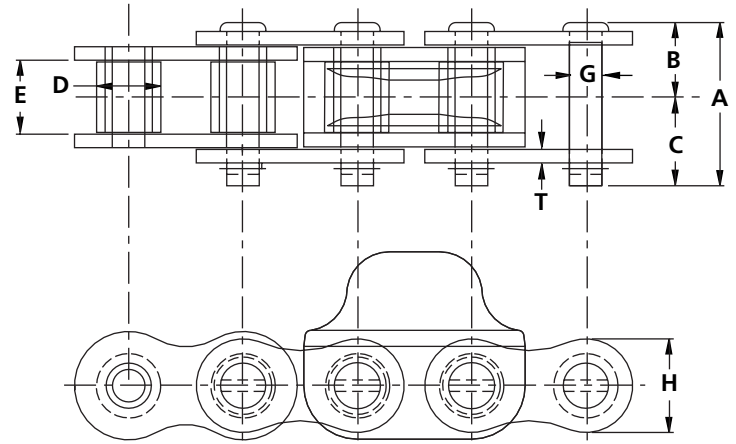
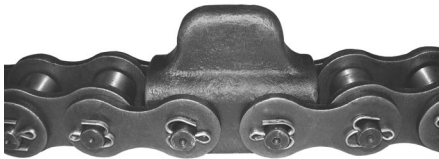

Promac caterpillar drive chains are vital in driving drop forged chain conveyors, so they must deliver fatigue free operation.

Key qualities are:

- High quality roller chain.
- Drive dogs made of one piece forged induction hardened for wear.
- These chains meet ANSI standards.

Caterpillar Drive Chain Specifications

All dimensions are inches unless otherwise indicated

Chain Number	Pitch	Chain Width				Diameter		Sidebars		Drive Dog Pitch Spacing	Avg. Ult. Strength (lbs.)	Approx. Weight (lbs./ft.)
		Overall	Pin Head to CL	Pin End to CL	Inside Width	Roller	Pin	Thickness	Height			
		A	B	C	E	D	G	T	H			
160/458	2.000	2.64	1.23	1.41	1.25	1.13	.56	.25	1.90	4 or 6	58,000	8.3 or 10.0
160/678	2.000	2.64	1.23	1.41	1.25	1.13	.56	.25	1.90	6	58,000	9.8

Dimensions shown are nominal. Obtain certified prints for design and construction.